

# Secure Doc Executive

• 60 minutes fire protection for documents

*Did you appreciate the Secure Paper Cooler but were concerned about the smaller capacity? With the Secure Doc Executive from SecureLine, you have the ideal combination of a traditional safe design, value and fire protection. Suitable for any home or business environment, the safe protects a wide range of documents (e.g. passports, insurance documents and contracts). Offering 60 minutes fire protection, the safe also provides electronic and key locking options, fittings as standard and a choice of four sizes. Such product advantages illustrate SecureLine's commitment towards providing "the best value security solutions"...*

## Models

- The Secure Doc Executive is available in four models, all designed to protect your documents against fire
- Model 30 and 36 are compact designs, but offer very efficient storage capacity
- Model 52 and 76, the larger safes in the range, are suitable for storing binders vertically



## Locking

- The safes are provided with a user friendly electronic pin-code lock or security key lock
- The electronic lock provides the possibility to program two user codes and has a sophisticated design
- Modern technology provides a hold up function when an incorrect code has been entered five times

## Certification

- The Secure Doc Executive range is tested and certified to UL 72 Class 350 and NT Fire 017 60 P

## Additional features

- Anchoring points in base allow safe to be fixed to floor
- As standard, the safes are supplied with a shelf and / or special tray to store small items
- Additionally model 76 is equipped with a lockable drawer

## Design

- The safes range will complement any user environment and are supplied in a modern two-tone colour finish of light grey and dark grey



from **Chubb**safes

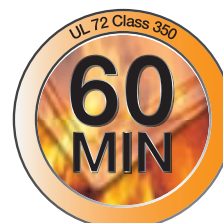

# Secure Doc Executive

## Models

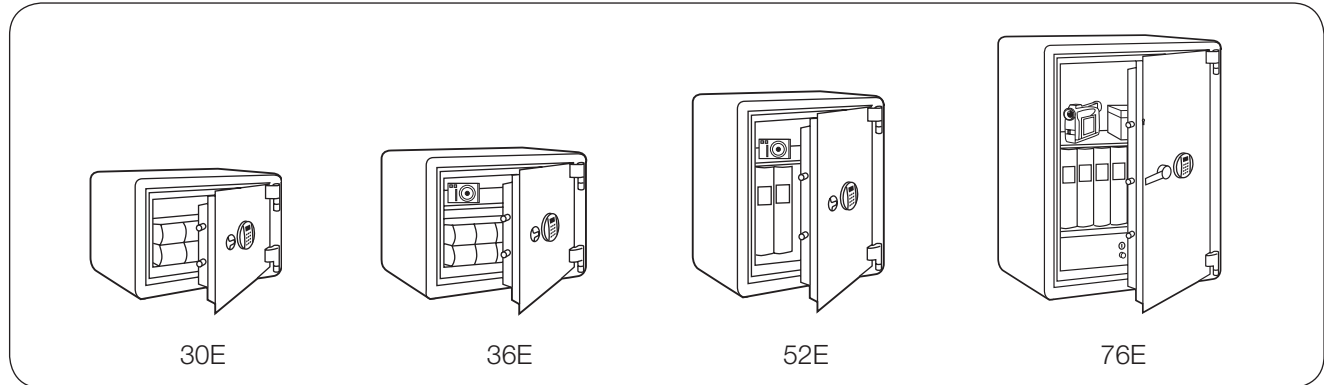

## Product data

### Key lock

Model	Article No.	External dimensions (mm)			Internal dimensions (mm)			Volume Weight		Fittings (qty)			Fire Rating (mins)
		Height	Width	Depth	Height	Width	Depth	(litres)	(kg)	Shelf	Tray	Drawer	
SDE-30K	SL03620	296	390	320	215	310	215	15	27	1	N/A	N/A	60
SDE-36K	SL03621	345	424	450	245	325	320	25	37	N/A	1	N/A	60
SDE-52K	SL03622	520	410	445	415	305	320	41	56	1	1	N/A	60
SDE-76K	SL03623	680	555	508	515	385	335	67	130	1	N/A	1	60

### Electronic lock

Model	Article No.	External dimensions (mm)			Internal dimensions (mm)			Volume Weight		Fittings (qty)			Fire Rating (mins)
		Height	Width	Depth	Height	Width	Depth	(litres)	(kg)	Shelf	Tray	Drawer	
SDE-30E	SL03600	296	390	320	215	310	215	15	27	1	N/A	N/A	60
SDE-36E	SL03601	345	424	450	245	325	320	25	37	N/A	1	N/A	60
SDE-52E	SL03602	520	410	445	415	305	320	41	56	1	1	N/A	60
SDE-76E	SL03603	680	555	508	515	385	335	67	130	1	N/A	1	60

SecureLine policy is one of constant improvement. The above specification may therefore be altered without prior notification.



from **Chubb**safes

Authorised dealer:



[www.SafeSecurityServices.co.uk](http://www.SafeSecurityServices.co.uk)

**0845 838 2448**